

XR2206 Function Generator manual install

1. Function Generator component layout diagram

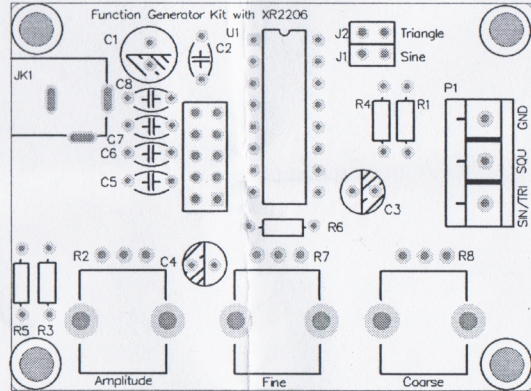

2. The Function Generator component parameter table

Note	label	type	parameters
R1	resistor	1K	Regardless of the polarity
R2	Adjustable resistance	B503=50K	(by screen printing layer)
R3,R5,R6	resistor	5.1K	Regardless of the polarity
R4	resistor	330	Regardless of the polarity
R7	Adjustable resistance	B503=50K	(by screen printing layer)
R8	Adjustable resistance	B104=100K	(by screen printing layer)
C1	Electrolytic capacitor	100UF	The positive long feet
C2	Non-polar capacitors	104	Regardless of the polarity
C3,C4	Electrolytic capacitor	10UF	The positive long feet
C5	Non-polar capacitors	105	Regardless of the polarity
C6	Non-polar capacitors	473	Regardless of the polarity
C7	Non-polar capacitors	222	Regardless of the polarity
C8	Non-polar capacitors	101	Regardless of the polarity
U1	IC	XR2206	(by screen printing layer)
JK1	DC POWER		(by screen printing layer)
J1	2PIN Jumper cap	XM2.54	Regardless of the polarity
J2	2PIN Jumper cap	XM2.54	Regardless of the polarity
P1	Signal wire terminal		(by screen printing layer)
P2	2*5P Jumper cap	XM2.54	

3. The welding installation considerations, follow these steps:

1. The components are welding the front board, from low to high principles, namely the first low welding components, such as, capacitor, resistor, diode, etc.
2. Welding IC socket, terminal blocks, finally power, socket, adjustable potentiometer
3. The back with a diagonal cutting pliers to cut short the pins as far as possible

4. Debugging steps:

1. After completion of welding on IC, XR2206, pay attention to the direction of IC, insert the might damage the chip!
2. check the IC whether against, such as anti please timely correction.
3. Insert the power supply, power supply for 5.5*2.1 port Center positive / barrel negative, For 9-12V power supply voltage. Supply more than12V, the output waveform is unstable

5. Using the step:

1. J1 jumper cap plug in, SIN/TRI blue terminals output sine wave(note J1,J2 can only insert one of)
2. J2 jumper cap plug in, SIN/TRI blue terminals output triangular wave(note J1,J2 can only insert one of)
3. SQU blue terminals output pulse
4. AMP: Sine wave, triangle wave amplitude adjustment
5. FINE: Frequency fine adjustment
6. Coarse: Frequency of coarse adjustment

6. Schematic diagram of Function Generator

